

IMMERSION THERMOCOUPLES

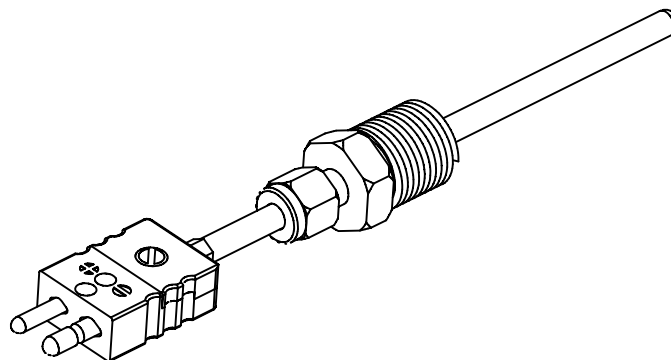
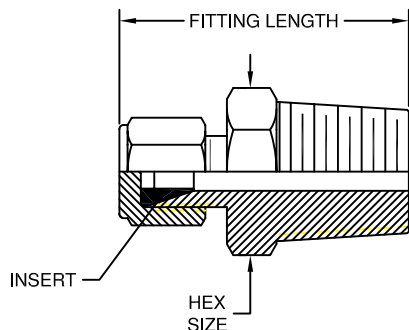

**BORE THROUGH BRASS
COMPRESSION TUBE FITTINGS**

**BORE THROUGH STAINLESS STEEL COMPRESSION
TUBE FITTINGS**

ORDERING CODE	PROCESS THREAD SIZE	SHEATH (TUBE) DIAMETER	INSERT MATERIAL	FITTING LENGTH	HEX SIZE
AF4350-1-B	1/8"NPT	1/16" (.063)	BRASS	1.03	7/16
AF4350-2-B	1/8"NPT	1/8" (.125)	BRASS	1.20	7/16
AF4350-3-B	1/8"NPT	3/16" (.188)	BRASS	1.23	7/16
AF4350-4-B	1/8"NPT	1/4" (.250)	BRASS	1.29	1/2
AF4173-4-B	1/4"NPT	1/16" (.063)	BRASS	1.23	9/16
AF4173-3-B	1/4"NPT	1/8" (.125)	BRASS	1.40	9/16
AF4173-2-B	1/4"NPT	3/16" (.188)	BRASS	1.43	9/16
AF4173-1-B	1/4"NPT	1/4" (.250)	BRASS	1.49	9/16
ORDERING CODE	PROCESS THREAD SIZE	SHEATH (TUBE) DIAMETER	INSERT MATERIAL	FITTING LENGTH	HEX SIZE
AF4350-1-T	1/8"NPT	1/16" (.063)	TEFLON®	1.03	7/16
AF4350-2-T	1/8"NPT	1/8" (.125)	TEFLON®	1.20	7/16
AF4350-3-T	1/8"NPT	3/16" (.188)	TEFLON®	1.23	7/16
AF4350-4-T	1/8"NPT	1/4" (.250)	TEFLON®	1.29	1/2
AF4173-4-T	1/4"NPT	1/16" (.063)	TEFLON®	1.23	9/16
AF4173-3-T	1/4"NPT	1/8" (.125)	TEFLON®	1.40	9/16
AF4173-2-T	1/4"NPT	3/16" (.188)	TEFLON®	1.43	9/16
AF4173-1-T	1/4"NPT	1/4" (.250)	TEFLON®	1.49	9/16

ORDERING CODE	PROCESS THREAD SIZE	SHEATH (TUBE) DIAMETER	INSERT MATERIAL	FITTING LENGTH	HEX SIZE
AF2485-4-S	1/8"NPT	1/16" (.063)	STN. STL.	1.03	7/16
AF2485-3-S	1/8"NPT	1/8" (.125)	STN. STL.	1.20	7/16
AF2485-2-S	1/8"NPT	3/16" (.188)	STN. STL.	1.23	7/16
AF2485-1-S	1/8"NPT	1/4" (.250)	STN. STL.	1.29	1/2
AF2502-6-S	1/4"NPT	1/16" (.063)	STN. STL.	1.23	9/16
AF2502-5-S	1/4"NPT	1/8" (.125)	STN. STL.	1.40	9/16
AF2502-4-S	1/4"NPT	3/16" (.188)	STN. STL.	1.43	9/16
AF2502-1-S	1/4"NPT	1/4" (.250)	STN. STL.	1.49	9/16
AF2817-6-S	1/2"NPT	1/8" (.125)	STN. STL.	1.87	7/8
AF2817-5-S	1/2"NPT	3/16" (.188)	STN. STL.	1.87	7/8
AF2817-2-S	1/2"NPT	1/4" (.250)	STN. STL.	1.87	7/8
ORDERING CODE	PROCESS THREAD SIZE	SHEATH (TUBE) DIAMETER	INSERT MATERIAL	FITTING LENGTH	HEX SIZE
AF2485-4-T	1/8"NPT	1/16" (.063)	TEFLON®	1.03	7/16
AF2485-3-T	1/8"NPT	1/8" (.125)	TEFLON®	1.20	7/16
AF2485-2-T	1/8"NPT	3/16" (.188)	TEFLON®	1.23	7/16
AF2485-1-T	1/8"NPT	1/4" (.250)	TEFLON®	1.29	1/2
AF2502-6-T	1/4"NPT	1/16" (.063)	TEFLON®	1.23	9/16
AF2502-5-T	1/4"NPT	1/8" (.125)	TEFLON®	1.40	9/16
AF2502-4-T	1/4"NPT	3/16" (.188)	TEFLON®	1.43	9/16
AF2502-1-T	1/4"NPT	1/4" (.250)	TEFLON®	1.49	9/16
AF2817-6-T	1/2"NPT	1/8" (.125)	TEFLON®	1.87	7/8
AF2817-5-T	1/2"NPT	3/16" (.188)	TEFLON®	1.87	7/8
AF2817-2-T	1/2"NPT	1/4" (.250)	TEFLON®	1.87	7/8
ORDERING CODE	PROCESS THREAD SIZE	SHEATH (TUBE) DIAMETER	INSERT MATERIAL	FITTING LENGTH	HEX SIZE
AF2485-4-L	1/8"NPT	1/16" (.063)	LAVA	1.03	7/16
AF2485-3-L	1/8"NPT	1/8" (.125)	LAVA	1.20	7/16
AF2485-2-L	1/8"NPT	3/16" (.188)	LAVA	1.23	7/16
AF2485-1-L	1/8"NPT	1/4" (.250)	LAVA	1.29	1/2
AF2502-6-L	1/4"NPT	1/16" (.063)	LAVA	1.23	9/16
AF2502-5-L	1/4"NPT	1/8" (.125)	LAVA	1.40	9/16
AF2502-4-L	1/4"NPT	3/16" (.188)	LAVA	1.43	9/16
AF2502-1-L	1/4"NPT	1/4" (.250)	LAVA	1.49	9/16
AF2817-6-L	1/2"NPT	1/8" (.125)	LAVA	1.87	7/8
AF2817-5-L	1/2"NPT	3/16" (.188)	LAVA	1.87	7/8
AF2817-2-L	1/2"NPT	1/4" (.250)	LAVA	1.87	7/8

REPLACEMENT INSERTS

REDUCING BUSHING

ORDERING CODE	SHEATH(TUBE) DIAMETER	INSERT MATERIAL
FRC6443-1	1/16" (.063)	TEFLON®
FRC6443-2	1/8" (.125)	TEFLON®
FRC6443-3	3/16" (.188)	TEFLON®
FRC6443-4	1/4" (.250)	TEFLON®
FR5712-3	1/16" (.063)	LAVA
FR5712-1	1/8" (.125)	LAVA
FR5712-4	3/16" (.188)	LAVA
FR5712-2	1/4" (.250)	LAVA

ORDERING CODE
RE1086-4

Size: 1/4"NPT Female by 1/2"NPT Male



SPECIFICATIONS

- Service: 5000 PSI @ 68° F.
- Fittings with Brass & Stainless Steel Inserts
Can not be relocated once tightened
- Fittings with Teflon Inserts
Can be relocated if used below 400° F.
- Fittings with Lava Inserts
Can be relocated if insert is replaced



TEMPERATURE MEASUREMENT DESIGNER'S GUIDE
WWW.THERMO-ELECTRIC-DIRECT.COM

SECTION IMTC ACCESSORIES

The information contained hereon shall be considered the sole property of Thermo Electric Company, Inc. The recipient thereof agrees not to disclose or reproduce said information to parties outside the recipient's organization without the written permission of Thermo Electric.

Doc. No.: TE-CO010109-IMTC-130